



Ergebnis-Fehler

**Wie viele
Denkfehler?**



overconfidence

**Marc ist ein schlanker Mann mit
Brille, der gern Mozart hört.**

**a) Er ist Literaturprofessor
in Zürich**

b) Er ist ein LKW-Fahrer

base-rate neglect

Missachtung der Grundverteilung





social proof

Herdenverhalten





**because
justification**

«Weil»-Irrtum





**effort
justification**

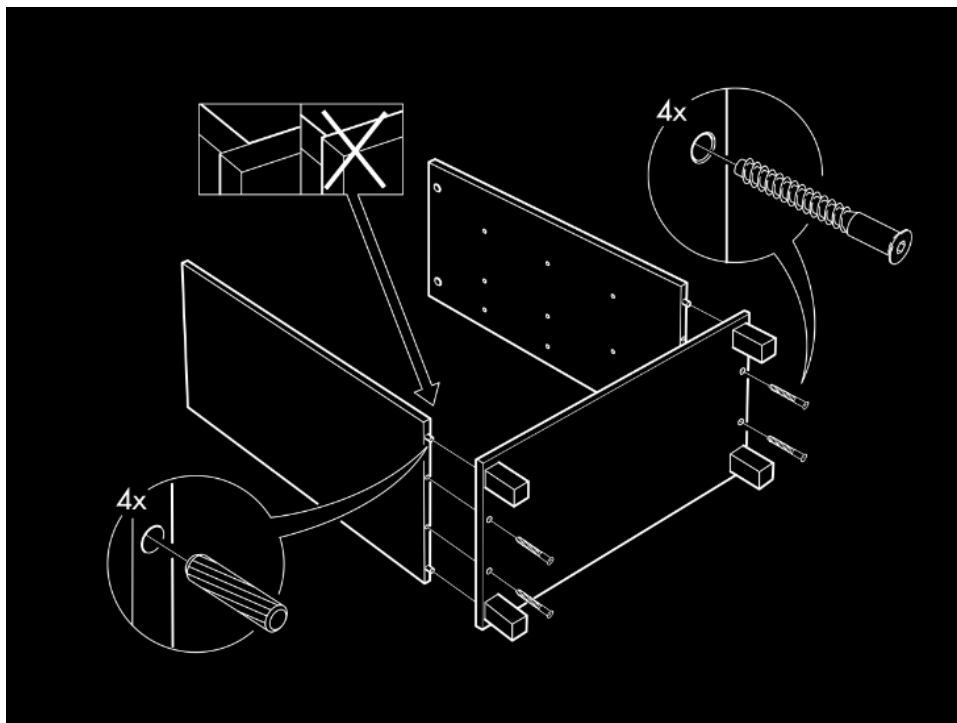



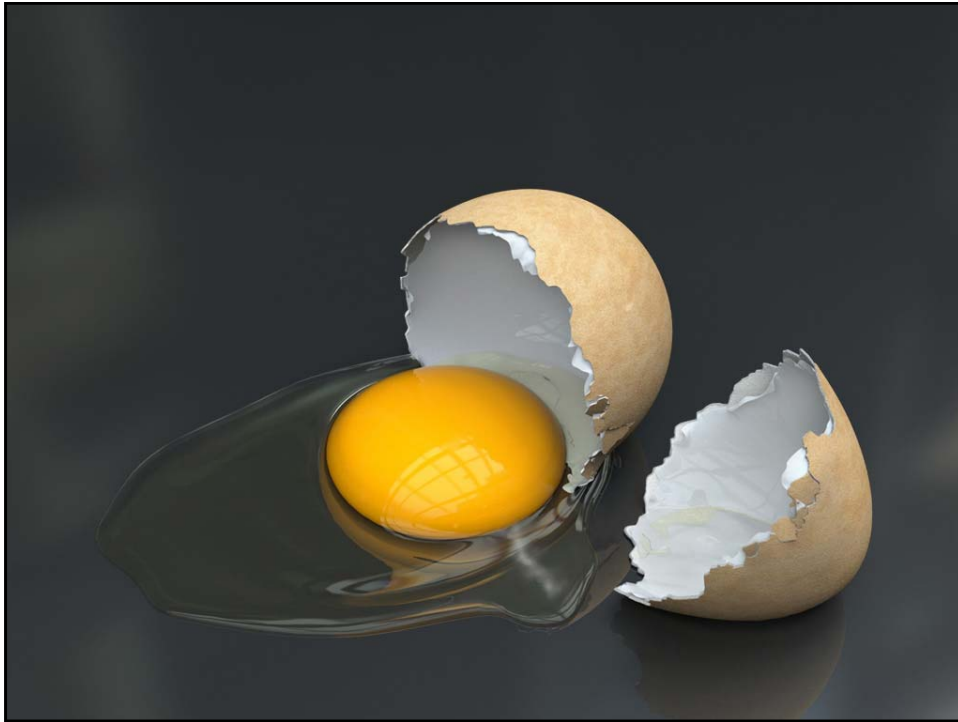

**Möchten Sie lieber
1000 Franken jetzt
erhalten oder 1050
Franken in einem
Monat?**

**Möchten Sie lieber
1000 Franken in einem
Jahr erhalten oder
1050 Franken in einem
Jahr und einem
Monat?**

**In beiden Fällen:
50 Franken für einen
Monat warten.**

Die verführerische Kraft des «Jetzt»



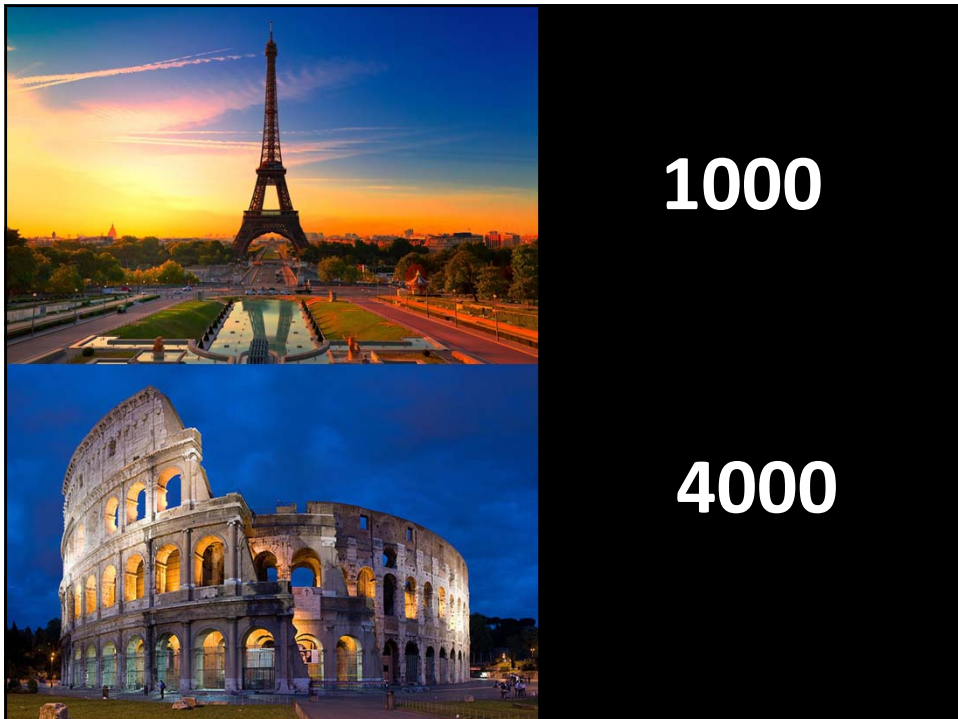

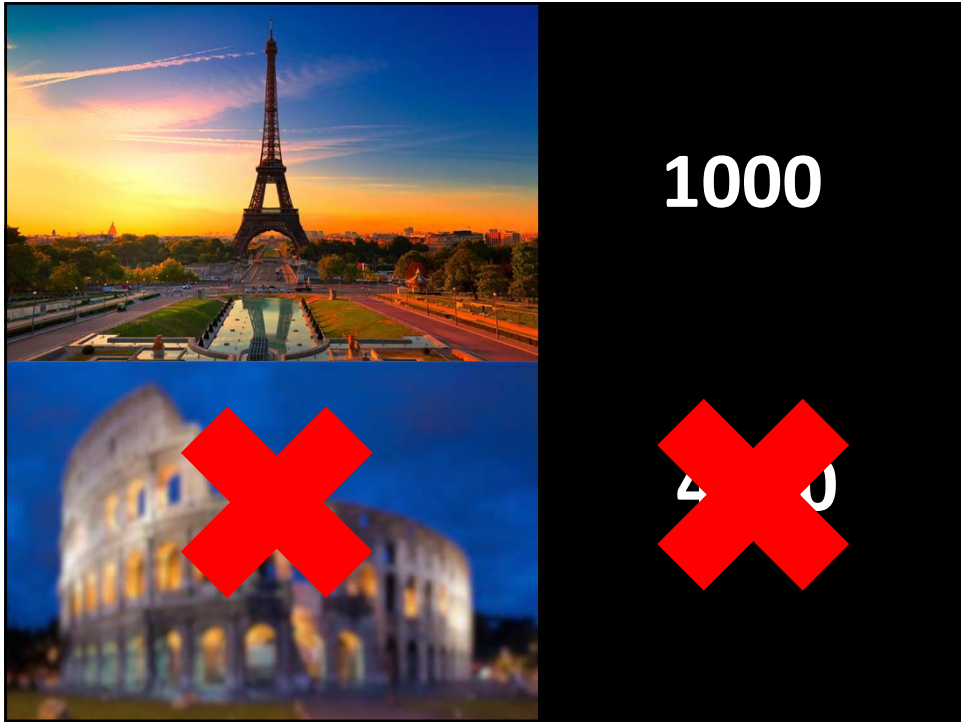

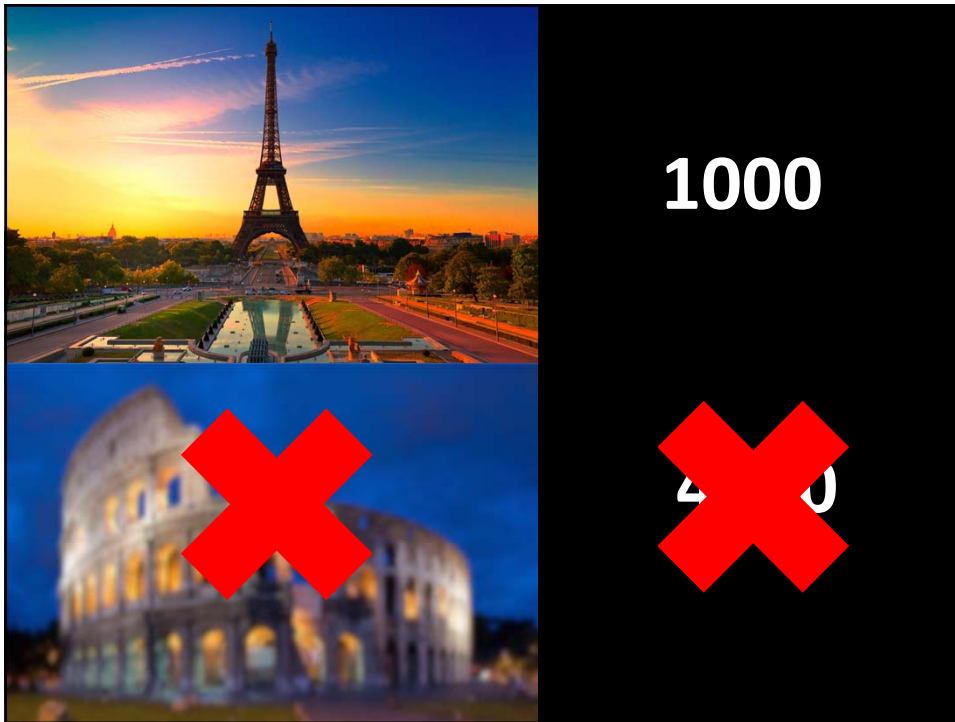





sunk cost fallacy





Ergebnisfehler
Overconfidence
Missachtung der Grundverteilung
Social Proof
Because Justification
Effort Justification
Die verführerische Kraft des Jetzt
Sunk Cost Fallacy

Herzlichen Dank !